

Microphones

The initial step in the sound recording process is the conversion of sound waves into proportional electromagnetic signals. The main type of transducer in audio recording is the microphone, the device that changes air pressure variations into voltages that vary in proportion to the sound amplitude and frequency. Two major classifications of microphones exist: those sensitive to the sound pressure and those sensitive to a pressure gradient between the front and back of the device. Many microphone designs respond to some of each characteristic and the balance determines their spatial sensitivity pattern. There are several mechanical types of microphone construction: dynamic (moving coil and ribbon) and capacitor (also known as condenser) being the main families. Choosing a microphone is much like selecting an instrument: there is no single ideal microphone for a given situation, but some types sound better than others for particular applications. Employing appropriate microphones and placing them in an optimal position relative to the sound sources makes the job of recording easier, since signal processing like equalization can be avoided if a particular microphone produces the desired sound directly. While it certainly helps to understand the basic principles of microphone design, there is no substitute for experience and experimentation.

Dynamic microphones: The simplest type of microphone in common use is the moving coil dynamic microphone. The signal is created when a coil of wire attached to a diaphragm in contact with the air moves in and out, through a fixed magnetic field, as the air pressure changes. An electrical signal is created by induction as the wires in the coil cut through the magnetic field. The output voltage is proportional to the velocity with which the coil moves through the magnetic field, making the microphone inherently sensitive to the air particle velocity resulting from the pressure difference between the front and back of the transducing element, which for a plane wave is in phase with the pressure:

$$e(t)=Blu(t)$$

where $e(t)$ is the instantaneous output voltage, B is the magnetic field strength (T), l is the length of the conductor (m) and $u(t)$ is the instantaneous velocity of the conductor (m/s).

Because sound waves consist of tiny pressure variations, the mass of the moving parts must be very low so that it does not require much force to move the diaphragm. The mass of the diaphragm assembly physically limits the high-frequency response of the dynamic microphone and may limit the overall sensitivity as well. The diaphragm and coil assembly exhibits mechanical resonance due to the interaction of its mass and compliance. The main resonance of the diaphragm is tuned using the resistance of mechanical damping while the frequency response may be tailored by introducing acoustical pathways to alter the air compliance at the extremes of frequency. The exact manner in which the tuning is accomplished varies from microphone to microphone and explains why similar dynamic microphones sound different.

Dynamic moving-coil microphones tend to be quite sturdy and of low cost, so they are commonly used to record drums, amplifier outputs, human voices, and other sources which produce high sound pressure levels. Another type of dynamic microphone is known as the ribbon microphone, since the transduction element is a metal ribbon open to the air on both sides that vibrates in a magnetic field to convert the sound input to a voltage. The basic ribbon microphone has a distinctive bi-directional (figure-eight) pickup pattern, although the pattern can be modified by altering the acoustical design of the microphone. Ribbon microphones tend to produce slightly better high frequency transduction than do moving coil types due to the decreased mass of the ribbon relative to a moving coil. They are, however, considerably more fragile than moving coil types and should not be exposed to wind blasts as might be produced by a voice or a kick drum, for example. Their output levels are significantly lower than moving coil designs.

Capacitor microphones: Also commonly called condenser microphones, these microphones function by making the diaphragm one plate of a capacitor while the other plate remains fixed. A large constant voltage difference between the plates is maintained by a power supply or through phantom power to charge the capacitor. As the diaphragm vibrates, it changes the capacitance of the capacitor in proportion to the sound pressure level. The diaphragm moves very little and is therefore, unless acoustically modified, inherently sensitive to air pressure rather than pressure gradient. The voltage produced by a capacitor microphone is approximately:

$$e = \frac{E_0 a^2 P}{8hT_0}$$

where e is open-circuit output voltage, E_0 is the polarizing voltage, a is the diaphragm radius (m), P is the pressure (Pa), h is the distance (m) from the diaphragm to the backplate and T_0 is the diaphragm tension (N/m). The capacitance change is due to the change in h as the diaphragm moves relative to the backplate. From the equation, we can see that the output voltage increases with increasing diaphragm radius and with decreasing diaphragm-to-backplate spacing and decreasing tension. Of course the situation is more complicated because the tension is also adjusted for controlling the resonances that affect the frequency response of the microphone. Different approaches to balancing these parameters lead to different sounding microphones. In capacitor microphones, the output voltage is inherently related to the displacement of the membrane rather than to its velocity.

The capacitance change is converted to a voltage by a special amplifier inside the microphone. As the capacitance changes and the polarizing voltage is held constant, current must flow from one plate to the other and that current is fed through a large resistance to generate a voltage signal. (Some capacitor microphones use high-frequency AC voltages to convert the capacitance change into a voltage.) Since this requires outside power, modern capacitor microphones require a battery or external power supply (known as “phantom” power because it is transmitted back over the same cable as the output signal by a special technique). Phantom power will be explained in more depth later. Some capacitor microphone designs that use vacuum tubes must operate from dedicated power supplies that can supply the high voltages required. In addition to the amplifier, the capacitor itself must be charged, so some electricity must be used to polarize the capacitor. In many inexpensive (and some very expensive) capacitor microphones, one plate of the capacitor is permanently charged. This is known as an electret condenser microphone. Unfortunately, the built-in amplifier requires power, so a battery or phantom power is still required. Since the mass of the diaphragm can be much lower than that of a dynamic diaphragm and coil, the capacitor microphone is usually better suited to high-frequency sound transduction, offering a somewhat more “transparent” sound quality. They are also potentially more fragile than dynamic microphones. Moisture and dirt collecting on the diaphragm can cause capacitor microphones to malfunction.

A novel type of microphone which has some special properties is the boundary-layer microphone or PZM™ (Crown). When a sound bounces off of a surface, it produces an interference pattern as the incident and reflected waves interact. This often causes irregularities when picked up by a microphone placed away from the reflecting surface. The boundary-layer microphone has a transducer element mounted in a plate which reflects sound. Because the active element is just at the boundary, the incident and reflected waves are in phase and do not produce a cancellation pattern. This results in a smooth sound and minimizes the effect of reflections. The active element in these microphones is usually a capacitor capsule due to the thinness required by the plate in which they must be mounted.

Directional Sensitivity

Polar patterns: Each microphone exhibits a pattern of directional sensitivity: that is, it is variably sensitive to sounds arriving from different directions. Sensitivity is measured in terms of voltage output for a given sound pressure level input. Patterns range from omnidirectional, in which every direction is equally well transduced (at least in theory), to bidirectional, in which sounds from the sides of the microphone are strongly rejected. By changing the acoustical construction of the microphone, the polar pattern can be altered to suit the desired use. Polar patterns can also be adjusted by combining two or more transducers electronically to produce the desired combination.

A sealed transducer element is sensitive to the absolute pressure at the front of the diaphragm or plate. When sensitive only to absolute pressure, the microphone is omnidirectional, since it cannot determine where in space the sound pressure originated. If an acoustical pathway for sound to reach the back of the diaphragm is provided, sounds originating from different directions may be forced to interact at the diaphragm of the microphone. By carefully tailoring the pathway, the microphone can be made to cancel sounds arriving from the rear or some other angle. The element is now said to be a pressure-gradient transducer, because it is sensitive to the pressure difference between the front and rear of the sensing element, both of which are then accessible to the sound wave. A pure pressure-gradient microphone responds to the resulting particle velocity and exhibits a bidirectional (figure-eight) polar pattern. Partially pressure-gradient sensitive microphones may exhibit cardioid, hyper-cardioid, and other direction-sensitive polar patterns, while pure pressure microphones are omnidirectional. Some polar patterns are shown in Figure 1 (the upward arrow indicates the front of the microphone):

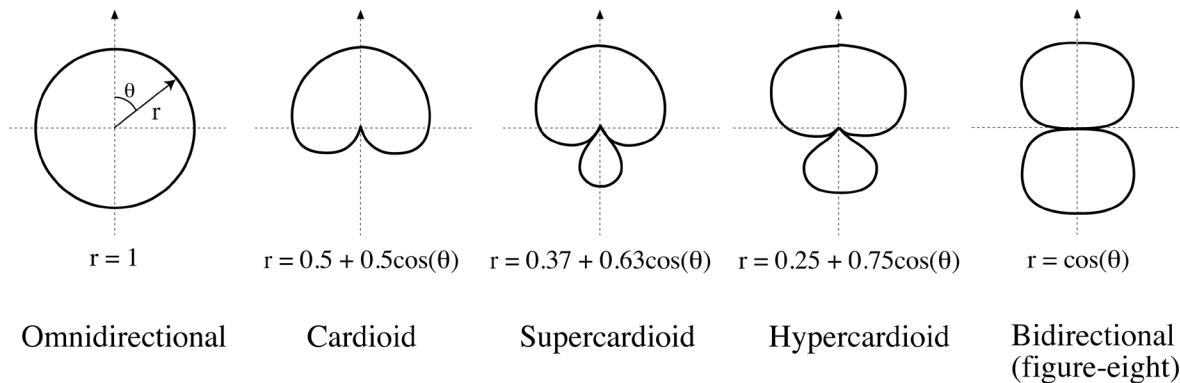

Figure 1: Polar patterns and their polar equations. The upward arrow indicates on-axis direction.

The sensitivity of the microphone to sounds from a particular direction is indicated by the length of the radius (r) from the center of the plot to the perimeter at the angle (θ) in question. In addition to the sensitivity, the frequency response of the microphone also varies as the angle of incidence of the sound changes. The so-called off-axis response affects the microphone sound as it filters, or “colors”, the sounds coming from the sides and rear of the microphone. This characteristic is complicated to describe, and the frequency-related polar plots often published by the manufacturers are somewhat difficult to interpret. Nevertheless, since the off-axis characteristics determine much of the overall sound of the microphone, an understanding of how the microphone “hears” sound will aid in the proper selection of a microphone for a given situation. The varying frequency response to sounds originating in different relative locations can cause multiple microphones in the same acoustic space to provide different and sometimes conflicting representations of the same original sound. These off-axis sound alterations can make mixing more difficult when the so-called leakage, or “bleed”, from different sources combine.

Polar patterns are simply descriptions of the directional sensitivity of microphones. The physical type of the transducer, while related, is not inextricably linked to the polar pattern. Capsules with different polar patterns can be combined in a single microphone to generate several switchable patterns. For example, two cardioid capsules may be mounted back-to-back: when the outputs are combined electrically, the pattern generated will vary from omni to cardioid to hypercardioid to figure eight depending on the relative contribution and polarity of each capsule. While this may give rise to a flexible microphone, it frequently results in less than perfect representations of the ideal polar patterns.

An interesting and important aspect of the directional sensitivity of microphones relates to their ability to focus on a sound source in the presence of extraneous ambient sounds. Ideally, we would like to be able to pick up a musical instrument's sound in an auditorium full of people without also recording the coughing and rustling of the crowd as we are able to do optically with a telescope. Our auditory system is very good at ignoring sounds we decide are extraneous by using the directional information to identify and ignore its source, something a microphone does not do. A directional microphone helps to some extent, as it is more sensitive to sounds from a particular direction, but it does not "ignore" any sounds completely. The ability of a microphone to pick up sounds from the front while rejecting sounds from other directions is known as its random energy efficiency (REE). REE is a measure of direct sound transduction versus ambient sound transduction. A related measure is the distance factor, or "reach", which is a measure of the distance from the sound source at which the direct to ambient sound pickup is equivalent. The distance factor is a measure of how much further from the source a particular polar pattern may be placed in order to produce the same ratio of direct to ambient sound as an omnidirectional microphone. Figure 2 compares the distance factor (d.f.) for several common polar patterns. The hypercardioid pattern has the best (longest) reach, while the omnidirectional pattern has the poorest. The reach of a hypercardioid allows one to record an instrument from a greater distance than would be possible with an omnidirectional, which often results in a better balanced sonic representation of the instrument's overall sound than could be obtained from closer miking.

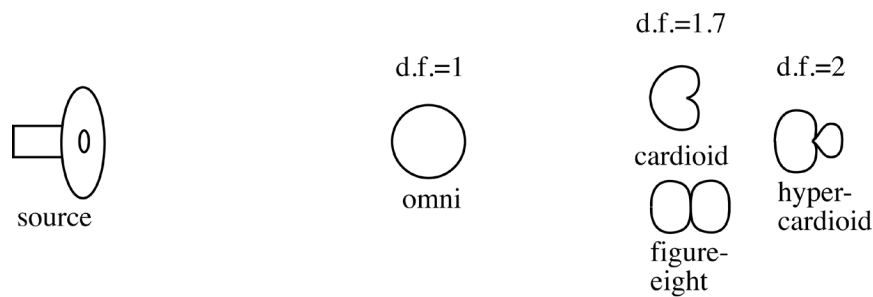

Figure 2: Distance factor for several polar patterns. Each microphone produces the same ratio of direct to reflected sound at the relative distances shown.

Another measure of directional sensitivity is the angle of acceptance, which describes the angle from which the microphone picks up sounds within a specified sensitivity. The angle of acceptance may be used to determine the amount of overlap in coverage needed to assure a stable image in stereo miking situations.

Most microphone data sheets give a frequency response curve plot for the on-axis direction. Some include the full two-dimensional x-y plot for the entire frequency range of the microphone. This is valuable information: the off-axis frequency response usually deviates significantly from the on-axis response, particularly in inexpensive directional microphones. This is a characteristic that can predict how the off-axis sounds interact when several microphones are mixed to produce a single output as is done in the mixing stage of a recording project. The accumulation of off-axis sounds can quickly muddy a mix if each microphone produces a distinctly different sounding bleed.

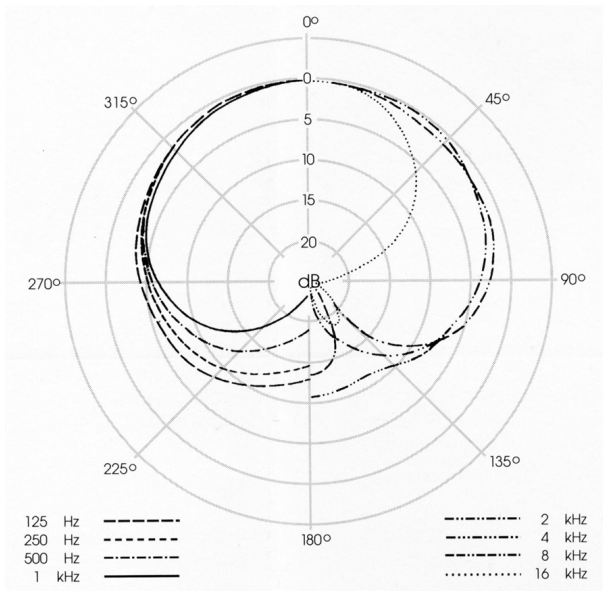

Figure 3: Off-axis frequency response for a good cardioid microphone.

Phantom power

While dynamic microphones generate an electrical signal directly, capacitor microphones require active circuitry to convert the capacitive changes in the capsule into voltages that can drive a preamplifier. Some inexpensive capacitor microphones power their internal electronics from a battery, but most use a system known as phantom power to draw power from the preamplifier itself. Phantom power is sent to the microphone using the same electrical connections through which the signal flows. This clever trick requires some attention when using phantom-powered microphones so as not to interfere with proper operation of both the microphone and the preamplifier input. Since both signal wires are raised to 48 volts relative to the shield, the receiving input needs to be isolated from the DC voltage. One consequence of using phantom power is that the connection must be a balanced, or differential, one and the shield must be connected at both ends. Care must be exercised so that a phantom-powered microphone is not connected or switched on while the input channel is audible to avoid damaging speakers and ears. For solid state preamps that don't use a transformer input, capacitors must be present between the microphone signal lines and the preamp input, which in that case is likely to be an op-amp. Although the differential amplifier op-amp circuit would reject the DC common to both inputs, there is a common-mode voltage limit for op-amp ICs that is often less than 48 volts. Figure 4 shows how phantom power is employed both for transformer and solid-state inputs.

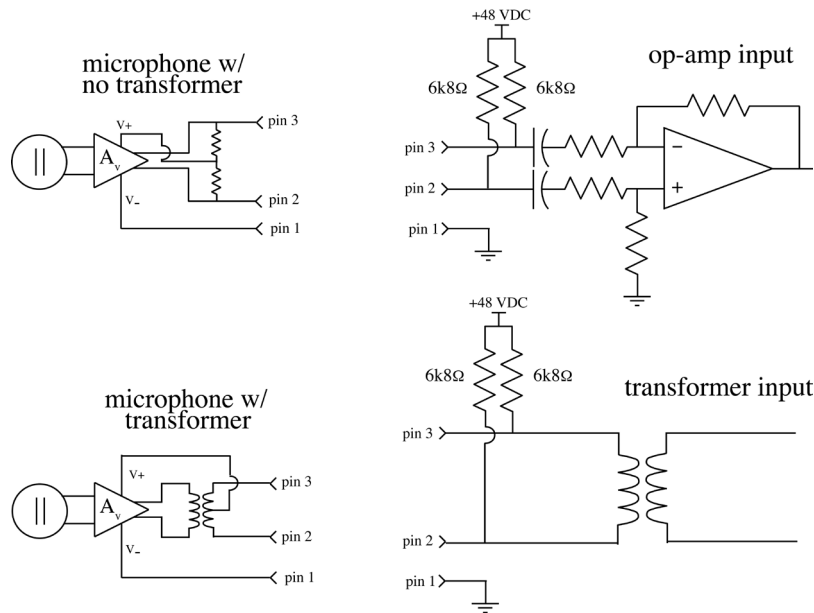

Figure 4: Phantom power circuits. Solid state inputs require capacitive coupling to keep the DC from reaching the preamp input.

Comparing Microphone Sensitivities

We must decide between a bewildering array of possibilities when we choose a microphone for a specific task. Some valuable information can be hidden in those cryptic data sheets so thoughtfully provided by the manufacturer. Unfortunately, the critical information is frequently encoded into the specifications in different ways, making comparisons difficult (the more skeptical engineer might suspect this is done on purpose...). The main criterion for comparison would involve the microphone's sensitivity: how much signal is produced by a given sound pressure level (SPL)? Two other considerations involve the amount of noise inherent in the microphone and the spacial sensitivity (polar pattern).

To compare the sensitivity of two microphones, their stated output must be measured relative to a standard pressure input. There are, unfortunately, several reference pressures commonly used, making a conversion necessary to get a direct comparison (or we could just plug both mics in and see which one is louder for the same gain setting on the mic preamp). The most directly useful sensitivity rating would be volts/dB SPL. What we frequently get is something like -75 dB re: 1V/mbar. A helpful conversion factor is:

$$1 \text{ newton/m}^2 = 10 \text{ dynes/cm}^2 = 10 \text{ mbar} = 1 \text{ pascal} = 94 \text{ dB SPL} \quad (\text{all are units of pressure})$$

In order to compare microphone sensitivity specifications, they must be converted to the same reference: then the relative output levels can be directly compared. Relative sensitivity can roughly be deduced by examining the input trim adjustment necessary to produce the same meter reading for two microphones in the same place.

Along with sensitivity, other considerations include the noise level generated by the microphone and the maximum sound pressure that can be accepted without distortion. The inherent noise in a microphone is often reported as "self-noise" or equivalent input noise. This is usually given as the sound pressure level in decibels that would be required to generate the observed output noise voltage. Noise in dynamic microphones is generated by random thermal processes that are impedance related, hence the low-impedance of most such

microphones. Overloads in dynamic mics are generated by the physical limits of the diaphragm, which is mechanically damped, allowing very high sound pressure levels (up to 140 dB SPL) to pass undistorted. Noise in capacitor microphones is mostly generated in the internal electronic circuitry. Overloads usually occur at the limits of the electronics power supply voltage rather than due to physical excursion limits in the capsule. Even capacitor mics can usually handle SPLs up to 130 dB SPL, with some capable of transducing SPLs up to 160 with the use of internal pads (attenuators). Capacitor elements ultimately overload when the diaphragm touches the backplate, which usually destroys the capsule.

Size Matters

There is a lot of speculation about the size of a microphone's diaphragm and its behavior with regard to low and high-frequency transduction. The question is usually whether a small-diaphragm or large diaphragm microphone is better for a given application. In order to understand the difference between large and small diaphragm mics, we need to think about how the sound pressure couples to the diaphragm. This is what will determine how accurately the microphone converts the sound into an electrical signal.

When the wavelength of the sound approaches the dimensions of the microphone, the interaction begins to be affected by shadowing, diffraction and resonance effects of the air molecules interacting with the diaphragm surface. We would like the microphone to act as a point source transducer, so that its dimensions are negligible with respect to the dimensions of the sound pressure waves. As the frequency of the sound increases, the dimensions of the microphone become closer to the wavelength of the pressure waves. This causes the microphone diaphragm to behave less like a point or piston and more like a drum head, where the resonant modes of the diaphragm may be excited by the sound and no longer be independent of frequency. In this regard, small diaphragms will behave independently at higher frequencies than will larger diaphragms. Generally, small (1/4" to 1/2") omnidirectional microphones will deliver the most accurate transduction at high frequencies and are often used for critical recordings like string quartets or a capella singing groups.

So what's the reason large diaphragm microphones are so popular for vocals? One drawback to small dimension transducers is that they tend to have lower output levels, and hence higher self-noise. For quiet singers this is an issue. But the main reason large diaphragm microphones seem to work so well on vocals has more to do with their idiosyncratic "imperfections", which give them a pleasant, albeit non-linear, frequency response with resonant peaks at the right frequencies to emphasize parts of the spectrum that just make the human voice sound big and warm. This may be due at least in part to the resonant behavior of larger diameter of the diaphragm. Designing and building these diaphragms is as much an art as a science.

Philosophy and Microphone Selection

Why are there so many kinds of microphone and how can we choose the right one? This question comes up time and again as people begin to make recordings and seek to improve their recorded sound. First of all, there is no "right" microphone for a certain application. Frequently, a capacitor microphone will be selected because it is expensive and therefore, should "sound better" than a dynamic microphone. The truth is that the dynamic microphone might actually sound better. The only way to get a feel for the art of microphone selection is to try a lot of different microphones in a lot of different situations and get experience in the way the mics behave. The more situations one encounters, the wider their experience and the better they become at getting a good sound. While the guidelines given above provide a starting point, they should not be taken as gospel. There is much lore about microphones, since so many recording engineers have stories about the "sweetest U47" they

ever heard, the SM-57 that survived a 40' drop with no discernable damage, and so forth. The truth is that some microphones are used widely and successfully, while others acquire cult status, complete with mystical attributes. The bottom line is that great recordings may be produced with a wide range of microphones, from the lowly SM-57 on up to multi-thousand-dollar 50 year-old Neumann and Telefunken vacuum-tube capacitor microphones. The best engineers are able to make good recordings with whatever equipment is available to them, and do not become "microphone snobs". And often, the microphone selection provides only a part of the answer: the placement of the microphone can be as important as the choice of microphone. By careful selection and placement, the need for equalization can be minimized or eliminated. By moving the microphone around and carefully listening, it is often possible to find a placement that sounds noticeably better. Often a change of inches will produce a dramatic change in the sound. It is not unusual to spend hours getting a drum set microphone array adjusted to produce the best possible sound. And it is frequently the case that fewer microphones do a better job than too many: microphone interactions may make it more difficult to get a desirable sound. The best way to approach microphones is with enough technical knowledge to make educated selections, and the patience to try many different microphones and placements in order to capture the sound you want. Finally, it all comes down to your ears: let them be your arbiter.

Possibly due to the proliferation of inexpensive digital multitrack recorders, many microphone manufacturers have been developing less expensive, high quality microphones to meet the growing demand from home studio owners. A notable example is the Neumann TLM-102 cardioid capacitor microphone, which sells for under \$1000, less than half the price of their previous microphones. Many of these new lower-priced transformerless microphones lack multi-pattern capabilities or other features, but for their intended use can produce excellent sound transduction. With the trend toward offshore manufacturing has come a flood of very inexpensive condenser microphones. While they may resemble the famous German models, their manufacture is not of the same quality and there often seem to be quality control issues. Nonetheless, many of these \$100-200 microphones are quite useable in some situations. The ability to use our ears and judge the best options for recording has never been more important.

Some Important Cautions

As you might expect, microphones are fragile. They can be damaged by excessive sound pressure exposure as well as by physical shocks like dropping. Dirt, dust and moisture can degrade microphone performance dramatically, so such exposure should be avoided. It is necessary for the engineer to consider this in selecting and deploying them. Unfortunately, it seems the more expensive a microphone, the more fragile. Capacitor and ribbon microphones are generally less sturdy than standard dynamics. This should always be considered in selecting microphones for demanding tasks like drum, amplifier, and even vocal recordings. Another potential problem area is the microphone stand adapter, the little device which attaches the microphone to the stand. They are often plastic, even on relatively expensive microphones. It is important not to cross-thread the adapter when screwing it to the stand. Always be gentle: if it feels like it doesn't fit, back it out and start again. CCRMA's microphone clips and stands are fitted with quick-release adapters (Atlas Sound LO-2B) to facilitate rapid microphone changes - please don't remove them. While these adapters make switching microphones easy and reduce the likelihood of cross-threading, they should be carefully checked to be sure they are correctly locked. Also, consider the weight of the microphone on the boom stand when setting up so that the mic doesn't pull the boom down, causing the microphone to hit the ground or some other massive stationary object. There's no better way to ruin your rapport with a studio (including CCRMA's!) than to damage one of their prized microphones, so always treat microphones with respect.

Phantom power is necessary for capacitor microphones but is not required for dynamic microphones. While phantom power will not hurt most dynamic microphones, some older ribbon microphones have been known to be susceptible to such damage. Best practice is to connect all microphones with phantom power off (don't "hot

plug” microphones) and then turn it on only for those channels that require it with faders down. Connecting 48 volts to a live input channel will generate enormous pops that can damage electronics, speakers and ears. Please be careful.

One special area of caution involves condenser microphones and moisture. Due to the very high impedances encountered in the capacitor transducer, condensation can short-circuit the capsule and compromise performance. Over time, material will build up on the capsule and change its mechanical properties. This is a problem especially while recording vocals with close-micing techniques, since moisture from breath condenses on the element easily. To prevent this, a pop screen or filter should be used between the singer and the microphone when the singer is very close (< one foot) and singing directly into the microphone. These have the added benefit of reducing plosive sounds (like p’s and b’s) tendency to overload the microphone but may slightly affect the sound quality. Unfortunately they also have the tendency to subtly change the sound, so more distant placement with no screen may be advisable, particularly with loud singers.

[Please treat our microphones with care. We all have to share them and any damage means the microphones will not be available to the whole community. If you should accidentally damage a microphone (or any CCRMA equipment), please report the problem to a staff member immediately.]

Stereo Microphone Technique

While the great majority of modern recordings make use of complex multitrack systems and instrument overdubbing, there remains a school of thought that simple stereo recording is preferable, especially for live recording. There are many ways to accomplish this, several of which make use of just two microphones. As one is soon to discover, however, it is not always as simple as putting two microphones in front of a musical group: the distance of each instrument as well as the individual instrument sound level outputs may vary too much to create a proper balance. Also, we are used to hearing stereo in a room with our two ears. We are “set up” to make use of two main clues about sound source placement: relative loudness and time-of-arrival. In fact, other more subtle information also contributes to our perception of the sound field: phase and spectral relationships within the complex sound pressure signal we hear can convey information about the height and front-to-rear placement of a sound source and interact with the pinna of the ear in a way unique to each individual. Unfortunately, microphones do not “hear” the same way we do and consequently the recorded signals may not always convey the original sounds the way we would have heard them when they are played back. The challenge of stereo microphone technique is to bring to the listener a convincing image of the actual sonic event.

Spaced Pair Technique

A-B pair Probably the most straightforward placement is referred to as A-B placement: two identical microphones are placed, at some distance apart, in front of the source. Omnidirectional microphones are frequently employed for this, although directional mics can be used. This system records both time-of-arrival and relative amplitude information, but if the microphones are spaced farther apart than our ears, which is almost always the case, the reproduced stereo field can be somewhat unnatural sounding. This might sound OK if we are usually listening on speakers which are also placed far apart. The stereo separation depends on the distance between the microphones, but a “hole” can be created in the middle of the stereo field if the microphones are too far apart. A third microphone is sometimes used in the middle of the spaced pair to prevent

this, but undesirable cancellations may occur if this is not done carefully. Individual microphones (sometimes called accent mics) can also be placed near a soloist and combined with the spaced pair if necessary. When using spaced pair recording techniques, it is important to consider the “3 to 1 rule” in order to minimize undesirable phase cancellations: the microphones should be placed at least 3 times as far apart as they are from the sound source. (Obviously, this is not possible for a point source...) Observing the 3 to 1 rule helps insure that phase cancellations will be reduced to an acceptable level, due to the inverse distance law that governs the dissipation of sound pressure with increasing distance. Not only is the interaction of the microphones important in stereo recording, but any time more than one microphone is used to pick up the same sounds, as in the case of multitrack studio recordings.

X-Y Technique

X-Y refers to the use of two closely-placed microphones when the outputs are simply recorded and not matrixed to produce the stereo sound. Many variations of this simple system of stereo microphone placement are possible, using directional microphones and either coincident or near-coincident placement.

Coincident pair When two directional microphones are placed together and aimed at an angle with respect to each other, a stereo recording can be created due solely to the amplitude differences, since the time-of-arrival (or phase relationship) will be the same for both mics. [This does not work with perfectly omnidirectional microphones, although most real omnis are not perfectly omnidirectional at all frequencies.] The technique is also known as single-point stereo microphone placement. Coincident placement can be used to record a single instrument in stereo, or it can be used for ensembles, but it may not be optimal for large groups since the far ends of the sound source may not be adequately picked up. When two bi-directional (figure-eight) microphones are used at a 90° angle, the system is known as a Blumlein pair. The Blumlein pair produces a very natural sound, but since the rear is picked up as well as the front, the placement is sensitive to sounds coming from the rear. This tends to work best in a good-sounding room without a restless audience.

Near-coincident pair A slight separation of a coincident pair can sometimes yield a pleasing stereo image, providing the soundfield is not too wide. The ORTF (the French National Broadcasting Organization) has devised the method of separating two cardioid microphones 7” at a 110° angle. This system yields a good localization and depth-of-field, since the capsules are close at low frequencies but adequately separated at higher frequencies to give some time-of-arrival information in addition to the relative level difference. Sounds arriving from far left and right may cause mono-compatibility problems because of the time difference, so experimentation may be necessary.

M-S Technique

M-S (mid-side) technique refers to coincident placement of a directional (M) and a figure-eight microphone (S) oriented at 90° so that the directional microphone faces the sound source. The outputs are processed in a matrix which produces sum and difference signals (M+S, M-S), which become the left and right signals. This system has two major advantages: when the signals are combined in mono, there is a cancellation-free output, since the side mic cancels and only the mid signal is reproduced. The other advantage is that the stereo separation can be controlled by the matrixing operation, allowing the stereo spread to be changed after the recording is made. The matrixing operation can be accomplished with a mixing console by panning the mid mic center and splitting the side mic into two inputs. One input is set to reverse the phase and panned to the right (M-S), the other is panned left with phase intact (M+S). By varying the mid to side mix, the stereo field width can be changed.

Soundfield Microphone Technique

A somewhat more complicated system which allows even greater post-recording manipulation of the sound

is the Soundfield microphone. It consists of four separate directional capsules mounted in the faces of a tetrahedron (three-sided pyramid) so that they aim at the odd-numbered corners of a cube: the elements are left-front up, right-rear up, right-front down, and left-rear down. These signals can then be matrixed to produce a wide range of simulated pairs, and some ambience as well. It is not quite as simple as the M-S technique, however, and takes a bit of experience (to say the least!) to understand what one is doing with this system. The Soundfield microphone output can be recorded directly as A-format or as processed B-format signals (called W,X,Y,Z) which may later be matrixed to produce a range of simulated stereo pairs.

Binaural Technique

A unique way of recording stereo is to simulate the human head, with microphones where the ears normally go, and listen with headphones. In many ways, this is the most accurate way of recording a sound in stereo. Unfortunately, there is one large drawback: it works poorly when reproduced on speakers. Several manufacturers make dummy head recording systems, which include head, ears, and shoulders. Condenser capsules are located in the ear canals. By placing the dummy in a hall, recordings which sound very much like “being there” can be made, provided one listens on headphones. Recently, systems have been developed which use digital signal processing to render the effect on speakers, but the system is rather complicated and expensive. A similar effect can be created by using two omnidirectional microphones about a head-width apart with Sonex or other sound absorbing material between them.

So what makes it stereo?

The key to capturing a stereo soundfield is similar to what allows us depth perception in vision: the overlap of sensory input from two separate sensors. Based on the cues we use to determine spatial placement of sounds, the way we select and position the microphones will determine how realistically we are able to reproduce the origins of the sounds we are capturing. Of course, in the real world there are lots of confounding factors which complicate the decision, like background noise, physical limits on where microphones may be placed, and limited time to try the alternatives.

The most convincing method of stereo recording is binaural, where a head with ears is approximated by the transducer system. This accurately reproduces both time-of-arrival and relative intensity cues, but requires headphones for optimal reproduction. Any of the other techniques compromise some amount of potentially important information. So we are left to decide which cues are dominant in a particular situation. Choosing between a coincident pair and spaced omni will finally come down to trying both and finding out what works best for you in a given situation. As usual, there’s no one right way but there are plenty of wrong ones. Experience is the best teacher.

Multi-channel multi-microphone recording

The same principles that govern stereo microphone practices are imposed when we use multiple microphones to record in the studio. The same phase cancellations we must consider when recording stereo are possible when we use several microphones on a drum set. These undesirable effects may be clearly audible when one microphone is soloed and compared individually with the other microphones in the array. If the sound changes when the two microphones are mixed together, there are probably cancellations occurring. In this situation, we do have some options: moving the microphones before recording is best, but after a recording is made delaying closer microphones so the time of arrivals line up sometimes reduces undesirable interference. Often a small

change in placement will make a large change in the interaction of the microphones, so some time spent on perfecting the setup will pay off in the final sound quality.

While impossible with analog recording, time alignment using digital recording and/or mixing is simple, at least conceptually: we can delay the close-miked sources until they align with the more distant ones. For the drum set example, we use the overheads as our main source and delay the snare and kick mics so that they now align with the overheads. Since sound travels about 1100 feet/sec, we can delay the close-miked channels about 1 msec per foot of distance from the overhead mics. While this sometimes tightens up the sound, it is by no means always necessary and since all the microphones pick up some of all the other sources at different distances/delays, perfect alignment is impossible. This is one reason fewer microphones often deliver a more focused sound than a large array. Another reason is the accumulation of off-axis pickup from the many microphones, each filtered differently by the off-axis response of the individual microphones. The more microphones combined, the greater the build-up of ambient sounds that can begin to mask other sounds and generally compromise the mix clarity.

©2006-2017 Jay Kadis (For Educational Use)

Some CCRMA Microphones



Shure SM-57
dynamic
cardioid [40-15kHz]



Shure Beta 57
dynamic
supercardioid [50-16 kHz]



Sennheiser MD-421
dynamic
cardioid [30-17 kHz]



Electrovoice RE-20
dynamic
cardioid [45-18 kHz]



Beyer M-500
dynamic ribbon
hypercardioid [40-18 kHz]



Shure KSM-141
condenser-phantom powered
cardioid & omni switchable
[20-20 kHz]



AKG C-414XLS
condenser-phantom powered
cardioid, omni, hypercard., figure-8
[20-20 kHz]



Neumann TLM-193
condenser-phantom powered
cardioid [20-20 kHz]



Neumann U-87Ai
condenser-phantom powered
omni, cardioid, figure-8
[20-20 kHz]



Josephson C42
condenser-phantom powered
cardioid [20-20 kHz]



Royer R-10
ribbon dynamic
figure-8 [30-15kHz]

Special Purpose Microphones



Electrovoice N/D 868
dynamic - kick drum
cardioid [20-10 kHz]



Sennheiser E-604
dynamic - clip-on drum
cardioid [40-18 kHz]

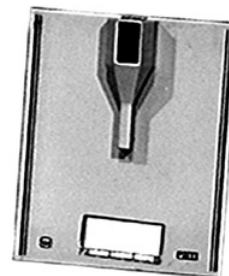

Crown PZM 30D
condensor-phantom powered
hemispheric [20-20 kHz]