

Integrated Ultrasonic Imaging Systems Based on CMUT Arrays: Recent Progress

I. O. Wygant, X. Zhuang, D. T. Yeh, A. Nikoozadeh, O. Oralkan, A. S. Ergun, M. Karaman*, and B. T. Khuri-Yakub
E. L. Ginzton Laboratory, Stanford University, Stanford, CA, USA
*Department of Electronics Engineering, Işık University, Istanbul, Turkey

Abstract— This paper describes the development of an ultrasonic imaging system based on a two-dimensional capacitive micromachined ultrasonic transducer (CMUT) array. The transducer array and front-end electronics are designed to fit in a 5-mm endoscopic channel. A custom-designed integrated circuit, which comprises the front-end electronics, will be connected with the transducer elements via through-wafer interconnects and flip-chip bonding. FPGA-based signal-processing hardware will provide real-time three-dimensional imaging. The imaging system is being developed to demonstrate a means of integrating the front-end electronics with the transducer array and to provide a clinically useful technology. Integration of the electronics can improve signal-to-noise ratio, reduce the number of cables connecting the imaging probe to a separate processing unit, and provide a means of connecting electronics to large two-dimensional transducer arrays. This paper describes the imaging system architecture and the progress we have made on implementing each of its components: a 16x16 CMUT array, custom-designed integrated circuits, a flip-chip bonding technique, and signal-processing hardware.

Keywords—ultrasonic imaging, capacitive micromachined ultrasonic transducer, CMUT, three-dimensional, systems, integrated circuits

I. INTRODUCTION

In existing ultrasonic imaging systems, the transducer array is often connected to the front-end electronics by lengthy interconnects. These interconnects add parasitic capacitance, are potentially lossy, and may necessitate impedance matching circuits. Furthermore, the interconnects make it difficult to connect large two-dimensional arrays to front-end electronics. By integrating the front-end electronics with the transducer array, the received signal can be buffered and amplified prior to these long connections, and large arrays can be compactly connected to electronics. If functionality such as beamforming, multiplexing, or analog-to-digital conversion can be integrated inside the probe, then the number of cables connecting the probe to an external processing unit can be reduced. This process is especially important for applications such as endoscopic imaging, where there is limited space for connecting cables.

This paper describes the development of an ultrasonic imaging system based on a two-dimensional capacitive micromachined ultrasonic transducer (CMUT) array. The transducer array and a custom-designed integrated circuit that comprises the front-end electronics are being designed to fit inside a 5-mm endoscopic channel. The inclusion of electronics within the transducer probe is made possible by a

compact and elegant connection scheme that utilizes through-wafer interconnects and flip-chip bonding. The transducer array and electronics will be connected to an FPGA-based signal-processing unit that will provide real-time three-dimensional image reconstruction. The imaging system is being developed to demonstrate a means of integrating the front-end electronics with the transducer array and to provide a clinically useful technology. This paper describes the imaging system architecture and the progress we have made on implementing each of its components: a 16x16 CMUT array, custom-designed front-end circuits, a flip-chip bonding technique, and signal-processing hardware.

II. SYSTEM DESCRIPTION

A diagram of the imaging system design is shown in Fig. 1.

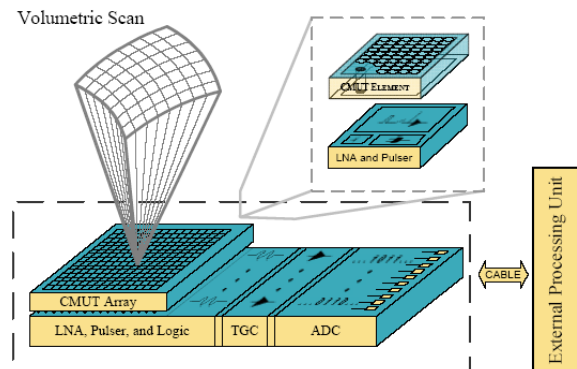

Figure 1. Diagram of the Integrated Imaging System

In the design, there are 16x16 CMUT elements in the transducer array. The elements have a 5-MHz transmit center frequency. Each element is connected to a 50- μ m diameter bond pad on the backside of the array with a through-wafer interconnect. The transducer array is flip-chip bonded to a custom-designed integrated circuit—the front-end IC. The front-end IC is composed of high-voltage pulsters for driving the transducer elements, low-noise preamplifiers for amplifying the received echoes, and digital logic for addressing and selecting between transmission and reception. The amplified signals from the front-end IC are passed to time-gain compensation (TGC) amplifiers and then to a signal-processing and data-acquisition system.

III. CMUT ARRAYS

A sacrificial silicon nitride process was used to fabricate several CMUT array designs for this project [1]. The CMUT arrays have 16x16 elements where, depending on the design, each element is 150- μm by 150- μm or 250- μm by 250- μm . The through-wafer interconnects are formed by creating 400- μm deep holes through the wafer with deep reactive ion etching (DRIE) [2]. A layer of thermal oxide is formed inside the hole to isolate the interconnect from the surrounding wafer. Polysilicon is then deposited in the hole and doped to provide conduction. Pictures of the fabricated CMUTs with through-wafer interconnects are shown in Fig. 2.

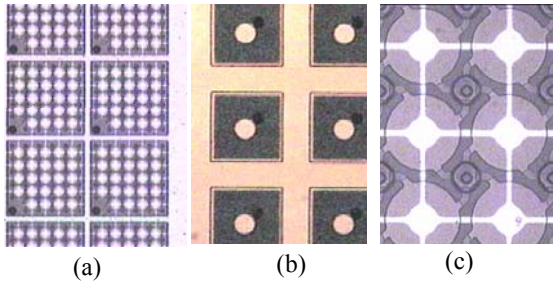

Figure 2. CMUT Array Elements a) Front Side b) Back Side c) Membranes

Fig. 2(a) shows a close-up of several 250- μm elements. For the design in this picture, each element consists of 24 membranes where each membrane is 36- μm in diameter. The top side of the through-wafer interconnect can be seen in the lower-left portion of each element. Fig. 2(b) shows the corresponding back side of the array where the opposite side of the through-wafer interconnect and a 50- μm diameter bond pad can be seen. Fig. 2(c) shows a close-up of six membranes.

To test the CMUTs, we excited them with a 30-V, 100-ns unipolar pulse and measured the transmitted pressure with a hydrophone. The received signal for a device tested in vegetable oil is shown in Fig. 3.

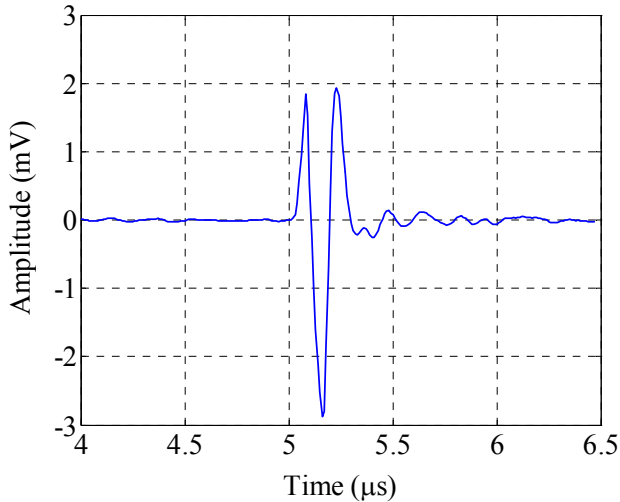

Figure 3. CMUT Response to a 30-V, 100-ns Pulse in Vegetable Oil

For the 30-V pulse, a transmit pressure of 100 kPa was measured. The normalized Fourier transform of the received

signal, adjusted for diffraction, attenuation, and the hydrophone response, is shown in Fig. 4. The Fourier transform is not adjusted for the spectrum of the driving pulse. The transmitted signal has a 3-dB fractional bandwidth of 95%, and a center frequency close to the design target of 5 MHz. To test the uniformity of the frequency response, an array was tested in air. The resonant frequency in air of each element was within 1% of the mean for the array. Several through-wafer interconnects were characterized. They had resistances of approximately 20 Ω and total parasitic capacitances, which include the bond pad and interconnect, of 0.2 pF or less.

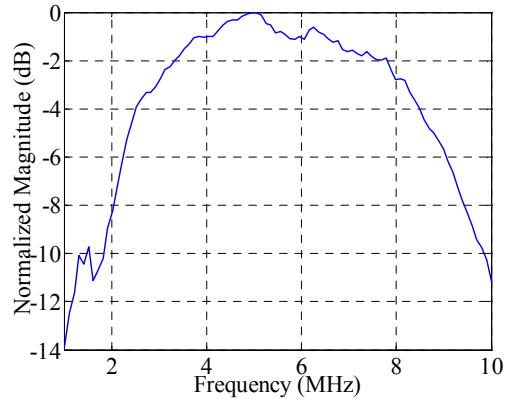

Figure 4. Spectrum of Signal Transmitted from CMUT

IV. FRONT-END ELECTRONICS

The front-end electronics encompass the pulser and preamplifier, TGC, and analog-to-digital conversion. For the initial demonstration of the system, only the pulsers and preamplifiers are included in the front-end IC. In previous work, we designed and implemented a multi-channel analog-to-digital converter (ADC) for integrated ultrasound systems [3]. Based on that work, we believe it is feasible to include the ADC with the front-end electronics. Its inclusion will provide noise immunity and could reduce the number of channels needed to connect the probe to an external processing system.

The pulser/preamplifier front-end circuit has evolved over several designs. For the first implementation, we designed the circuit to be wire bonded to a single transducer element. A simplified schematic of this design is shown in Fig. 5.

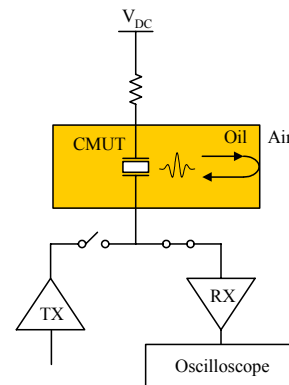

Figure 5. Pulser/Preamplifier Circuit

On transmission, a 5-V pulser excites the transducer. The preamplifier is protected from the pulse by an open switch. When receiving, the pulser is in a high impedance state and the transducer is connected to a transimpedance amplifier. This circuit was designed for a standard 0.25- μm CMOS process with a nominal supply voltage of 2.5 V.

Pulse-echo measurements were made with this circuit by wire bonding it to a 240- μm by 240- μm CMUT element. The echo received from a plane reflector at 1.2 mm had a 35-dB signal-to-noise ratio in a 50-MHz bandwidth. The echo signal is shown in Fig. 6.

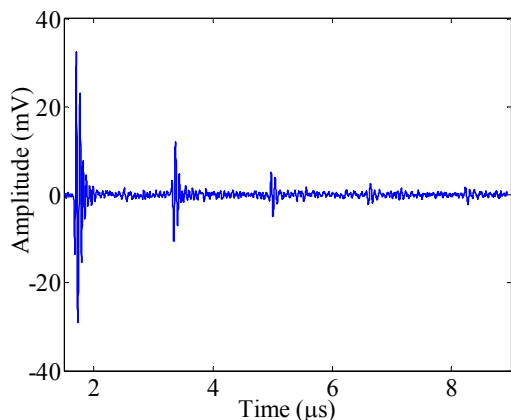

Figure 6. Echo from a Plane Reflector at 1.2 mm

For the second generation of front-end electronics, we are using a high-voltage analog process. We designed a column of 16 pulser/preamplifier circuits for flip-chip bonding to a single column of the two-dimensional CMUT array. In this design, a single-element in the column is active at a time for transmit and receive. When receiving, the preamplifier and output buffer are designed to consume 1.6 mW from a 5-V power supply.

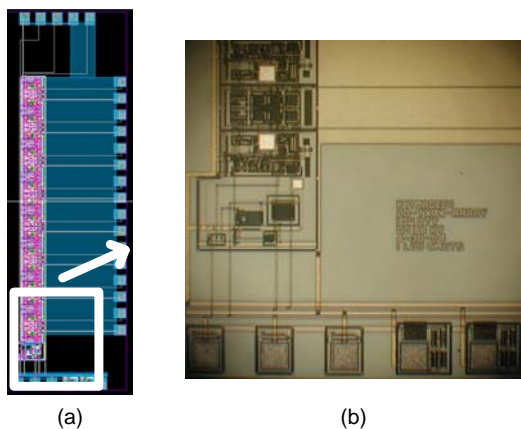

Figure 7. 16-Element Column of Front-End Electronics (a) Layout (b) Fabricated Circuit

Fig. 7(a) shows the layout for this design. Each pulser/preamplifier circuit in the column is 250- μm by 250- μm and matches the footprint of a single element in the CMUT array. Fig. 7(b) shows the portion of the fabricated device highlighted in 7(a).

The pulser is designed to generate 30-V, 100-ns pulses for a 2.5-pF load. A measured 28-V pulse is shown in Fig. 8.

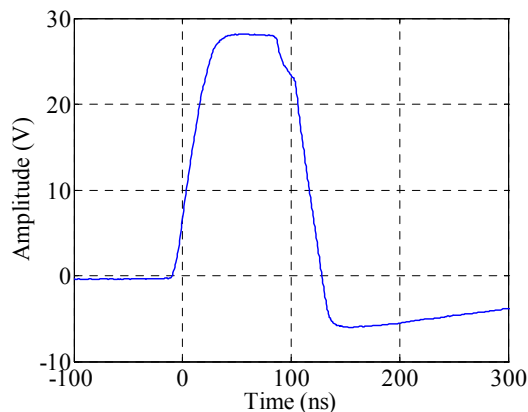

Figure 8. 28-V Transducer Excitation Pulse

Because of the way the preamplifier feedback resistors were drawn for the layout, the resistors did not function as designed. However, we were able to test the preamplifiers by bonding an external resistor to the circuit. Fig. 9 shows the output of the amplifier as it starts up after the pulser has fired.

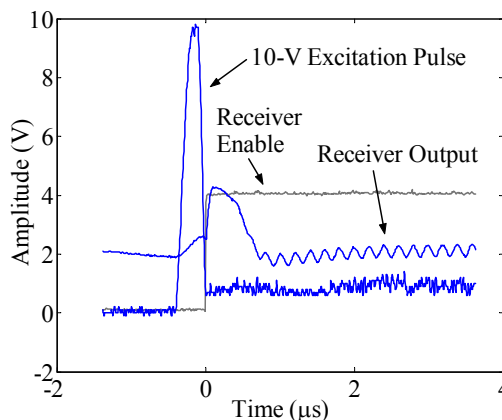

Figure 9. Preamplifier Startup

The 1.5- μs startup time is longer than expected due to the parasitic capacitance of the externally bonded resistor. From simulation, we expect a startup time of approximately 500 ns with an integrated resistor.

We recently completed the design of a new version of the front-end electronics. This version contains a 16x16 array of transmit/receive cells and is designed to be flip-chip bonded to a CMUT array for three-dimensional imaging. As in the single column of electronics, only a single transmit/receive cell is active at a time. However, because there is a transmit/receive cell for each element in the array, it would be straightforward to extend the design to transmit and receive on multiple elements. This extension will be explored in the future.

V. FLIP-CHIP BONDING

Flip-chip bonding is often used to connect integrated circuits to their packages or other circuits. We have used flip-

chip bonding in the past to connect CMUT arrays to printed circuit boards [4]. For this work, we use flip-chip bonding to connect the CMUT array elements to the front-end IC. The bonding process we use forms bonds between In and Au bumps. To bond to the aluminum IC bond pads, we first deposit a stack of metals on the IC. A diagram of the metal stack is shown in Fig. 10. The Ti and Cu layers provide adhesion and a diffusion barrier. With this metal stack, the IC pads can be bonded to the Au pads on the backside of the transducer array.

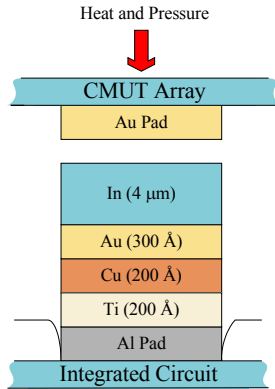

Figure 10. Metal Stack Used for Flip-Chip Bonding

A Research Devices M8-A flip-chip bonder is used to align the two pieces and press them together. A mass proportional to the total bonding area (approximately 30 grams per 50- μm diameter bond pad) is used to press the pieces together. During the bonding process, the pieces are heated at 150 $^{\circ}\text{C}$ for 30 seconds.

To test the bonding process, we fabricated and bonded a test structure. For all 30 connections in our test structure, the bond resistance was less than 10 Ω . The mean resistance was 3.4 Ω . Fig. 11 shows these results.

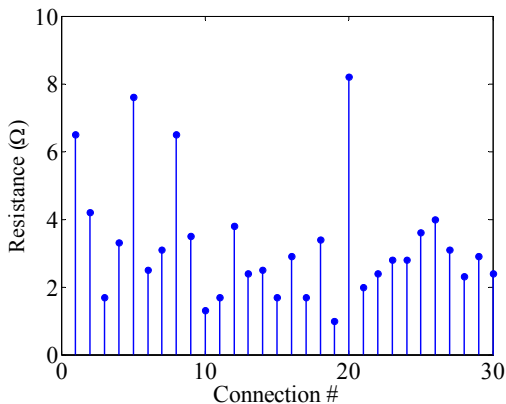

Figure 11. Resistance of Individual Flip-Chip Bond Connections

VI. DATA ACQUISITION HARDWARE

A commercial FPGA-based signal-processing system (Lyrtech Signal Processing, Quebec City, Canada) will be used for analog-to-digital conversion and image reconstruction. This system has 16-channels of 100-MSPS, 14-bit analog-to-

digital converters. Data from these ADCs flow into a Xilinx Virtex II 6000 FPGA. The FPGA will be used to control the transmit/receive sequence, element addressing, and for real-time image reconstruction.

VII. CONCLUSION

The architecture of a real-time volumetric imaging system based on a two-dimensional CMUT array was described. We have made progress in implementing each component of the system. CMUT arrays with 16x16 elements were fabricated and characterized. Through-wafer vias with 20 Ω of resistance and 0.2 pF of capacitance were used to connect the transducer elements to flip-chip bond pads. Pulse-echo measurements were made with a single-element, low-voltage version of the front-end IC. Front-end electronics designed for transducer arrays have been fabricated and tested. In preparation to flip-chip bond the CMUT array to the front-end IC, we have flip-chip bonded test structures. The bond resistance for each of the 30 connections in the test structure was less than 10 Ω . Finally, we have chosen a commercial system for data acquisition and signal processing.

The next step is to demonstrate imaging with the front-end electronics designed for the two-dimensional array. Additional work includes programming the signal-processing system for real-time image reconstruction and expanding the front-end electronics so that multiple elements are used for transmit and receive. Ultimately, with help from our collaborators in the Stanford Medical School, we intend to provide a clinically useful device for endoscopic ultrasonic imaging.

ACKNOWLEDGMENTS

We would like to thank National Semiconductor for the fabrication of the integrated circuits. We would also like to thank Bill Broach and the members of the Portable Power Group at National Semiconductor for valuable circuit and process discussions. The National Institutes of Health funded this work. Xuefeng Zhuang is supported by a Weiland Family Stanford Graduate Fellowship. David Yeh is supported by a National Defense Science and Engineering Graduate Fellowship.

REFERENCES

- [1] A. S. Ergun, C. -H. Cheng, U. Demirci, and B. T. Khuri-Yakub, "Fabrication and characterization of 1-dimensional and 2-dimensional capacitive micromachined ultrasonic transducer (CMUT) arrays for 2-dimensional and volumetric ultrasonic imaging," in *Oceans '02 MTS/IEEE*, 2002, vol. 4, pp. 2361-2367.
- [2] C. H. Cheng, E. M. Chow, X. Jin, S. Ergun, B. T. Khuri-Yakub, "An efficient electrical addressing method using through-wafer vias for two-dimensional ultrasonic arrays," in *2000 IEEE Ultrasonics Symposium*, 2000, pp. 1179-1182.
- [3] K. Kaviani, O. Oralkan, P. Khuri-Yakub, B. A. Wooley, "A multichannel pipeline analog-to-digital converter for an integrated 3-D ultrasound imaging system," *IEEE J. Solid-State Circuits*, vol. 38, pp. 1266-1270, July 2003.
- [4] O. Oralkan, A. S. Ergun, C. -H. Cheng, J. A. Johnson, M. Karaman, T. H. Lee, B. T. Khuri-Yakub, "Volumetric Ultrasound Imaging Using 2-D CMUT Arrays," *IEEE Trans. Ultrason., Ferroelect., Freq. Contr.*, vol. 50, pp. 1581-1594, Nov. 2003.