

THE SIMULATION OF MOVING SOUND SOURCES¹

John M. Chowning

The Center for Computer Research in Music and Acoustics (CCRMA)

Stanford University, Stanford, CA 94306

jmc165@sbcglobal.net

ABSTRACT

A digital computer was used to generate four channels of information, which are recorded on a tape recorder. The computer program provides control over the apparent location and movement of a synthesized sound in an illusory acoustical space. The method controls the distribution and amplitude of direct and reverberant signals between the loudspeakers to provide the angular and distance information and introduces a Doppler shift to enhance velocity information.

1. INTRODUCTION

The normal experience in listening to music and other acoustic signals is to have a continuum of sound source locations. This includes the direct signals from the locations of the sources and the indirect or reverberant signals from the surrounding environment. However when music is produced for loudspeakers (synthesized music), the number of sound source locations is determined and limited by the number and location of the loudspeakers.

In conventional stereophonic reproduction and in the more recent four channel reproduction of music recorded in an enclosed space, the directional and distance cues of the various recorded sound sources are to some extent preserved, giving an illusion of location in an illusory acoustical space. In music which is synthesized, however, including electronic music, computer music, and some of the newer popular music, the techniques to project the location of a synthesized sound in an illusory space have not been defined to the extent that the total effect is in any way comparable to a good stereophonic or four channel recording.

The intent of this paper is to give some focus to the problem of synthesizing a sound source in an illusory space and in particular a moving sound source, by defining a technique with which reasonably convincing spatial images can be produced.

2. LOCALIZATION CUES

In order to locate any real sound source in an enclosed space the listener requires two kinds of information: that which defines the angular location of the source relative to the

listener, and that which defines the distance of the source from the listener. The cues for the angular location are:

- (1) the different arrival time or delay of the signal at the two ears when the source is not centered before or behind the listener,
- (2) the pressure-level differences of high frequency energy at the two ears resulting from the shadow effect of the head when the source is not centered.²

The cues to the distance of a source from a listener are:

- (1) the ratio of the direct energy to the indirect or reverberant energy where the intensity of the direct sound reaching the listener falls off more sharply with distance than does the reverberant sound,
- (2) the loss of low intensity frequency components of a sound with increasing distance from the listener.

2.1. The Simulation of Cues

The following defines the configuration of loudspeakers and listener and the means by which the angular location and the distance cues may be simulated.

In this system four loudspeakers are placed so that they form the corners of a square, the perimeter of which forms the inner boundary of an illusory acoustical space, as shown in Figure 1. The listener is located inside of this boundary as close to center as possible. Because the localization cues are computed for the listener who is an equal distance from the four loudspeakers there will be a geometric distortion of the spatial image for any other listener depending on his distance from center. In the case of stereo simulation the relative location of the listener to loudspeakers 1 and 2 is assumed (Figure 1).

2.1.1. Angular Cues (*Azimuth*)

As in normal stereophonic and four channel listening, the precise location of the listener is not known, which means, therefore, that any cues to location of a source that are dependent upon delay, phase, and orientation of the listener's head are not appropriate. The cue to angular location, then, must be introduced by a changing energy ratio of the direct signal applied to a loudspeaker pair.

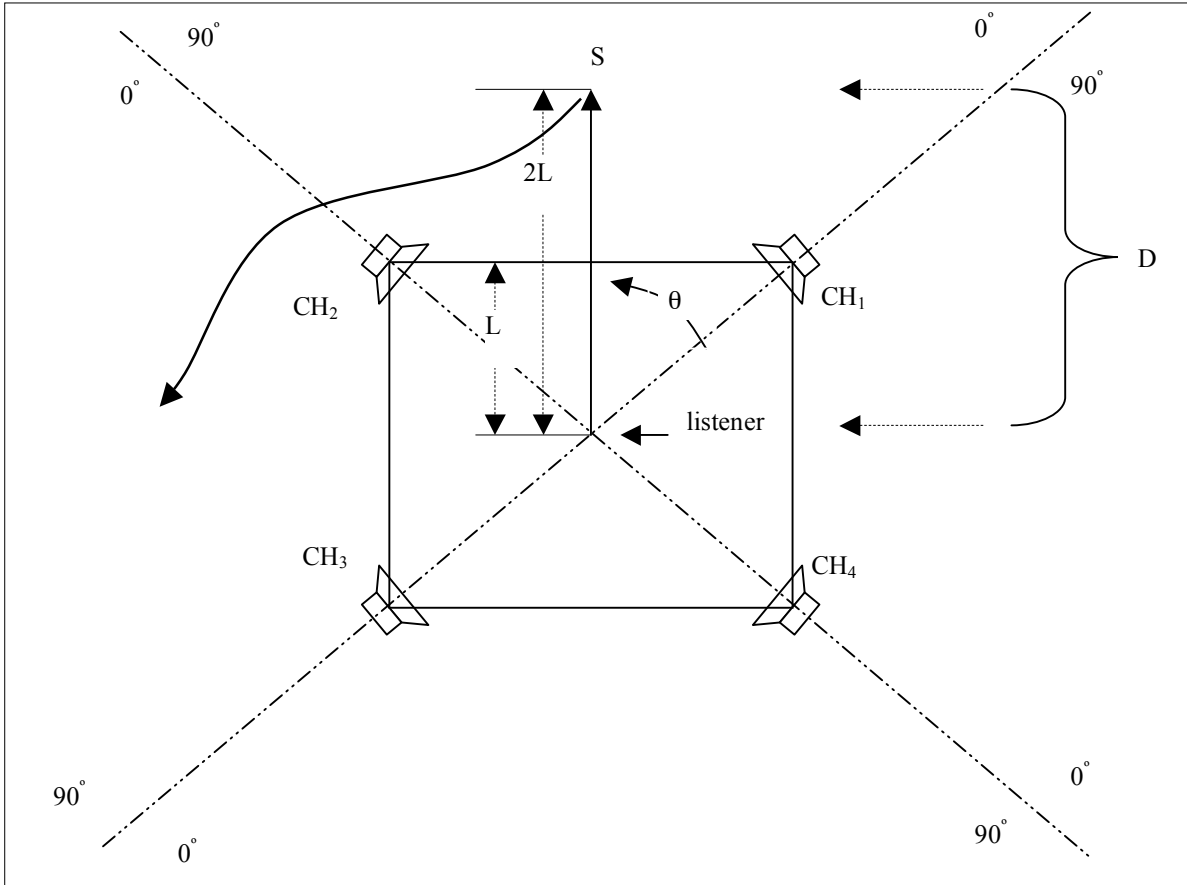

Figure 1. Configuration of loudspeakers defining illusory space and listener space.

As shown in Figure 1, the 360-degree space is divided into the four quadrants where each pair of loudspeakers is at an angle of 90 degrees relative to the listener. The obvious means of changing the ratio of the direct signal for the moving sound source S, is to make the energy applied to the loudspeaker pairs proportional to the angle of displacement. Thus,

$$\%SignalCH_1 = 1 - \frac{\theta}{\theta_{max}} \quad \text{and}$$

$$\%SignalCH_2 = \frac{\theta}{\theta_{max}} \quad \text{where}$$

$$\theta_{max} = 90^\circ$$

As the source moves into the adjoining quadrant CH₂ and CH₃ are substituted for CH₁ and CH₂ respectively.

It may be, however, that in simulating the location of a single source with two virtual sources, a non-linear function might tend to "fill the hole" between the loudspeakers and de-emphasize the regions near the loudspeakers.

Making the energy ratio proportional to the tangent of the angle can produce such a function. Thus,

$$\%SignalCH_1 = 1 - \frac{1 + \tan(\theta - \frac{\theta_{max}}{2})}{2}$$

$$\%SignalCH_2 = \frac{1 + \tan(\theta - \frac{\theta_{max}}{2})}{2} *$$

2.1.2. Distance Cues.

In order to simulate the distances cue one must synthesize and control the reverberant signal as well as the direct signal such that the intensity of the direct signal decreases more with distance than does the reverberant signal. The amplitude of the direct signal is proportional to $1/D$ where D = distance and where the distance from the listener to the point midway between two loudspeakers is L . In Figure 1, the source S begins at a distance of $2L$. The amplitude, therefore, would be attenuated by $1/2$.

* Although both functions have been tried the listening conditions were not suitable for a definitive comparison of the two.

It is assumed that in a small space the amplitude of the reverberant signal produced by a sound source at constant

intensity but at varying distances from the listener changes little, but that in a large space it changes some. Therefore, in these experiments the amplitude of the reverberant signal is made

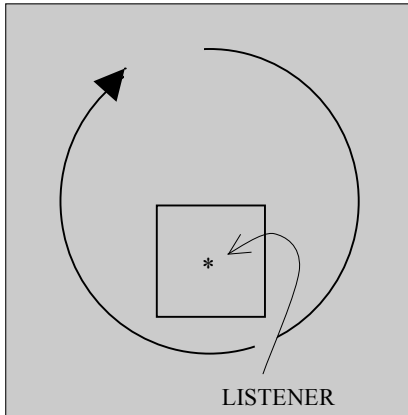

Figure 2. Sound path of a moving source (clockwise) around listener space.

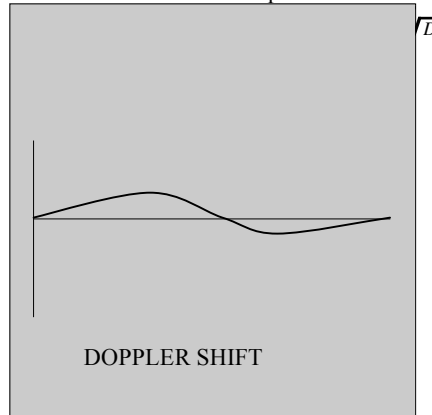

Figure 3. Control function for Doppler shift dD/dt .

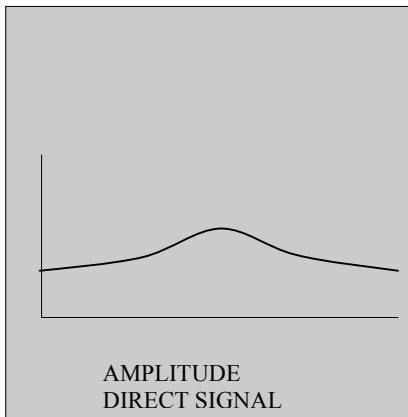

Figure 4. Control function for amplitude of direct signal $1/D$.

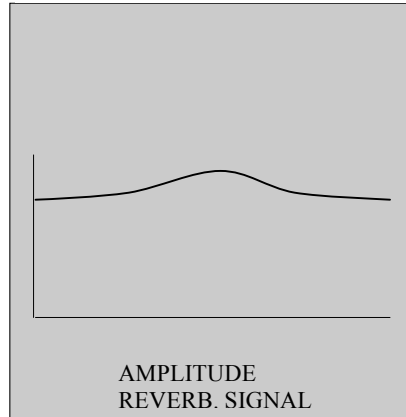

Figure 5. Control function for amplitude of reverberant signal. $1/\sqrt{D}$

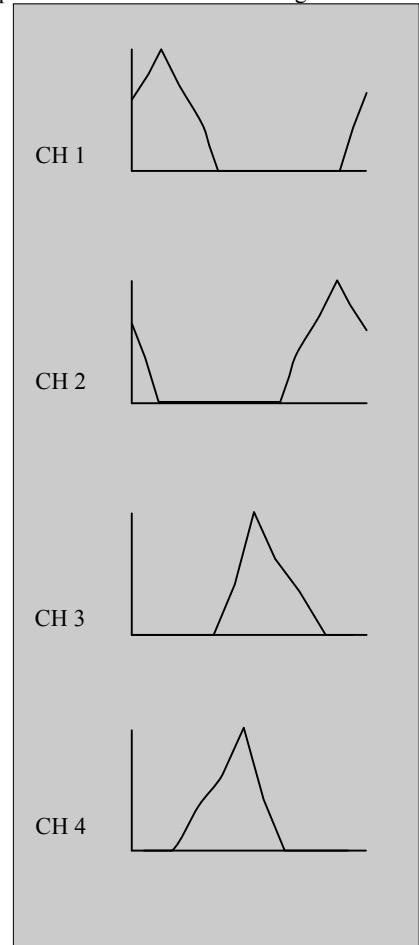

Figure 6. Control functions for angular displacement, CH₁ - CH₄.

2.1.3. Velocity Cues

In the presence of a moving sound source, a listener receives velocity information from the rate of the angular shift in energy (angular velocity), the rate of the radial shift in energy, and frequency shift due to the Doppler effect (radial velocity).

The simulation of the Doppler effect is achieved, simply, by scaling the unit distance D to some distance in feet and making change in frequency proportional to dD/dt .

3. REVERBERATION

As was noted above, reverberation is an essential part of the distance cue. Reverberation also supplies the 'room information'

giving general cues as to size, shape, and material construction. In simulating a sound source in an enclosed space, then, it is

desirable for the artificial reverberation to surround the listener and to be spatially diffuse.

To achieve the surround effect and the diffuse quality each output channel has a reverberator with independent delays and gains.³ In the simplest case some percent of the direct signal is scaled according to $1/\sqrt{D}$ and passed to the reverberators equally.

The percent governs the overall reverberation time within the limits determined by the values of the delays and gains of the reverberators themselves.⁴

It should be noted, however, that if the reverberant signal were to be distributed equally to all channels for all apparent distances of the direct signal, at distances beyond the echo radius⁵ the reverberation would tend to mask the direct signal and eliminate the cue for angular location. In order to overcome this deficiency the reverberant energy is controlled in the following two ways:

- (1) global reverberation, that part of the overall reverberant signal which emanates equally from all channels, is proportional to $1/D$ and,

- (2) local reverberation, that part which is distributed between a speaker pair, as is the direct signal, is proportional to $1 - \frac{1}{D}$.

Thus, with increasing distance of the apparent source the reverberation becomes increasingly localized, compensating for the loss of direct signal energy. In fact, this may be a fair approximation of a real acoustical situation, for as the distance of sound source increases, the distance to a reflecting surface decreases thereby giving the reverberation some directional emphasis.

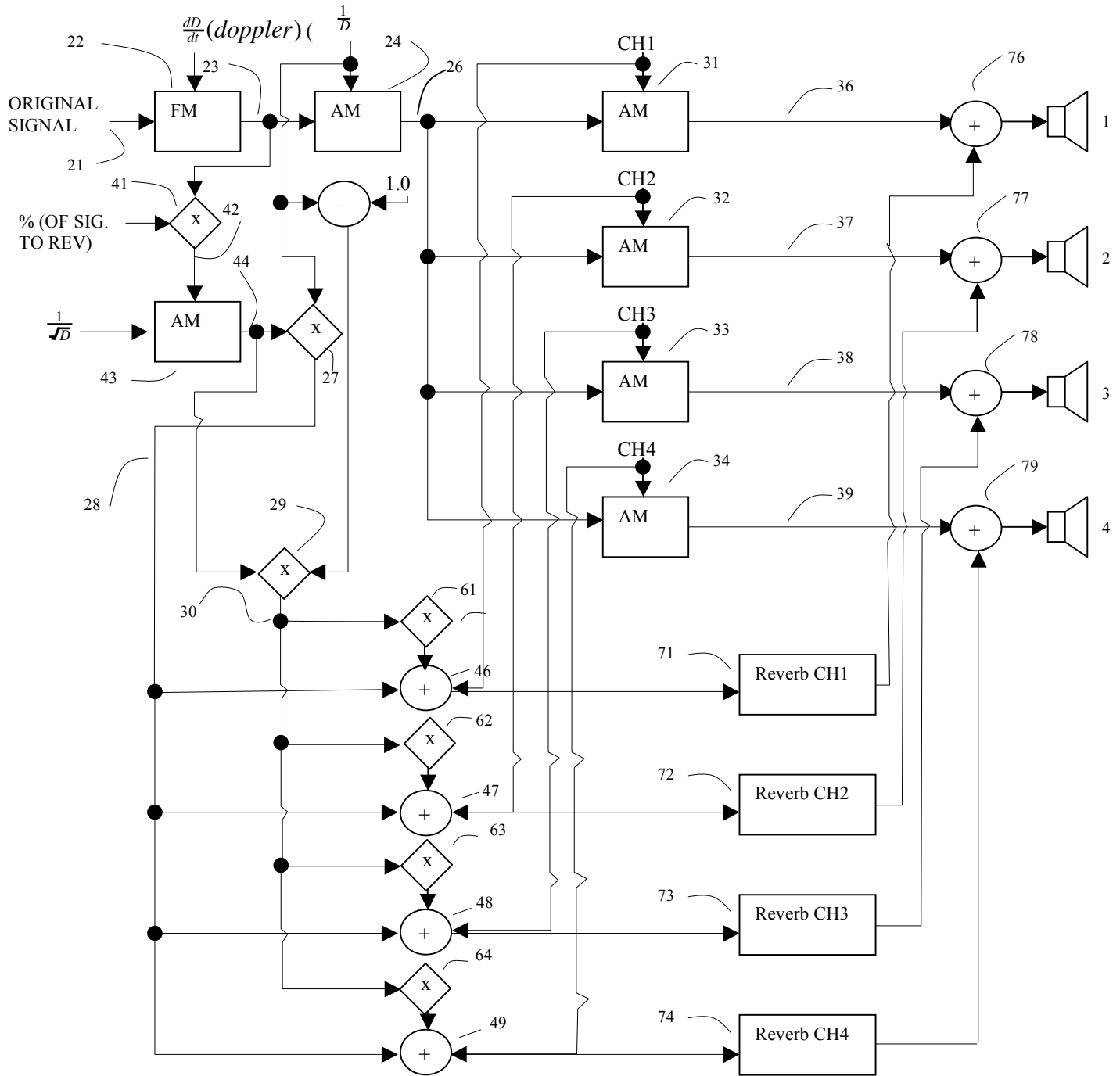

Figure 7. System to process signal using functions shown in Figures 3 – 6.

4. PROGRAM CONTROL

For the purposes of sound synthesis a special computer program was written which is similar to those that have been developed at Bell Telephone Laboratories.⁶ The program and system allow up to four output channels at a 25kc sampling rate per channel. The output signals are recorded on a four-channel recorder-reproducer.

4.1. Control Functions

In order to generate the control functions for a moving sound source, a special subprogram was written. The program uses a CRT to display a square, Figure 2, which defines the inner boundaries of the illusory space and a double-jointed arm whose position can be read by the computer. When the arm is moved, a pointer displayed on the CRT moves in a corresponding manner. The user presses a button as he moves the arm and simultaneously a point trace of the movement is displayed on the screen. Since the points are plotted at a constant rate their relative distance to each other indicates the velocity of the movement. The coordinates of the points are stored, the user types in a distance scale value for the Doppler shift, and the program then computes, displays, and stores the resulting control functions. The program also allows the option for computing a geometric sound path.

As shown in Figure 2, a nearly complete circular path is displayed where the center of the circle is the point midway between CH₁ and CH₂. Figure 3 shows the % frequency shift vs. time for a unit distance value of 20 feet and the source moving through the complete circle in 2 seconds. Figure 4 shows % amplitude vs. time (2 seconds) for control of the direct signal according to $1/D$. Figure 5 shows % amplitude vs. time for control of the reverberant signal according to $1/\sqrt{D}$. Figure 6 shows % amplitude vs. time for channels 1- 4, where the amplitude is proportional to $\tan\theta$ as described before. The sum of these four functions is equal to 1.

4.2. Processing

A diagram indicating the manner in which the above functions are applied in the sound synthesis program is shown in Figure 7. The original signal (21) is frequency modulated (22) for Doppler shift. The output (23) is amplitude modulated (24) for distance of direct signal, $1/D$. The signal (26) is then amplitude modulated (31-34) by the functions controlling angular location (CH₁₋₄). The outputs (36-39) are passed through adders (76-79) and then to loudspeakers (1-4).[†] Thus far, the direct signal has been processed for frequency shift, distance, and angle.

The frequency modulated signal (23) also takes another path to produce the reverberant signals. It is attenuated (41) by some % to control over all reverberation time. The output (42) is then

amplitude modulated (43) for distance, $1/\sqrt{D}$. This output (44) is modulated (27) by the distance function and the output (28) becomes the percent of the signal to become global reverberation.

The output at (44) is also modulated (29) by $1-1/D$ function. This signal (30) is then distributed in angle according to the same functions (CH1-4) that control the direct signal and added (46-49) to the global part. These four signals are then reverberated (71-74) and added to the direct signal (76-79). Multiple input adders can be placed immediately before the reverberators (71-74) and also replace those before the final output (76-79) to allow the simultaneous movement of a number of independent sources where the circuit (Figure 7) must be multiply defined only up to the reverberators and the final adders. This point is important because the reverberators cause by far the greatest expense, in computing time and memory, of the entire system.

5. SUMMARY

By using graphic input devices in conjunction with a powerful computer system a means has been developed by which an illusory sound source can be moved through an illusory acoustical space, allowing a great deal of flexibility and control. At some loss in flexibility but a gain in real time control the processing system can be rendered as an analog device. With some care in the design of the reverberators, some number of independent channels of synthesized music or recorded music, having a minimum of natural reverberation, can be transformed into two or four channels where the location - static or dynamic - of each input channel can be independently controlled in an illusory environment which can have a large range of reverberant characteristics.

6. ACKNOWLEDGMENT

The author wishes to express his appreciation to David Poole, Leland Smith, and Irwin Sobel for helpful suggestions made during the research and to Lucy Osby and Joe Zingheim for help in the preparation of the manuscript.

David Poole deserves special acknowledgement for the extraordinary contributions that he made to computer music at Stanford University. He not only wrote most of the version of Music IV that ran on the DEC PDP-6, but he taught this author all that I needed to know in the initial years in order to achieve the musical goals that we both shared. In 1999 he died at sea during a storm in Alaska, sailing ... a passion for which we both shared.

[†] It should be pointed out that the numerical representations of the waves are actually stored on a disk file and not converted to electrical energy and applied to the speakers until after the computation is completed.

7. REFERENCES

¹ First published: J. M. Chowning. The Simulation of Moving Sound Sources. J. Audio Eng. Soc. 19, 2-6, 1971.

² M. B. Gardner. "Binaural Detection of Single-frequency Signals in Presence of Noise," J. Acoust. Soc. Amer. 34, 1824-1830 (1962).

³ M. B. Gardner. "Image Fusion, Broadening, and displacement in Sound Localization," J. Acoust. Soc. Amer. 46, 339-349 (1969).

⁴ M. R. Schroeder. "Natural Sounding Artificial Reverberation," J. Audio Eng. Soc. 10, 219 (1962).

⁵ K. Wendt. "The Transmission of Room Information," J. Audio Eng. Soc. 9, (1961).

⁶ M. V. Mathews. The Technology of Computer Sound Generation, MIT Press, Boston (1969).